

Accurate Gas Measurement in Wet Gas Streams

Increasingly stringent air quality requirements have led to expanded use of wet scrubber systems to control air emissions. Chlorine storage facilities and chemical process plants are frequently required to scrub exhaust gas streams to remove halogen and acid gases.

Unfortunately, monitoring reactive gas concentrations in moisture saturated air streams presents problems for standard diffusion sensors. Condensing water in these air lines can quickly blind diffusion sensors, rendering them inoperable.

ATI's Series B12 Wet Gas System was developed to meet the need for reliable measurements in wet scrubber outlets for other gas streams that might be saturated with water vapor. Systems have been developed for monitoring strong oxidants (chlorine, bromine, chlorine dioxide, or ozone), acid gases (HCl or HF), and hydrogen.

The basic B12 Wet Gas System consists of a loop-powered 2-wire transmitter and a corrosion resistant

sensor specifically engineered to operate at 100% RH. Sensors are designed for direct insertion into vent stacks, or may be used in a flowcell if sample can be pumped to the sensor.

When remote display and alarm relay functions are required, the B12 Wet Gas Transmitters can be connected to ATI's B14 Alarm Receiver System. This system will provide direct digital display of gas concentration, plus 3 alarm setpoints, remote alarm reset input, and retransmitted 4-20 mA output. Or, the B12 transmitter may be used separately and tied directly to the users' DCS, PLC, or other equipment. Either way, the B12 is an excellent solution to a difficult monitoring problem.

Take a look at these features:

- Direct measuring sensor
- Minimal maintenance
- Rapid response
- Stack mount or flow-through sensor
- Transmitter LCD display option
- Loop-powered electronics

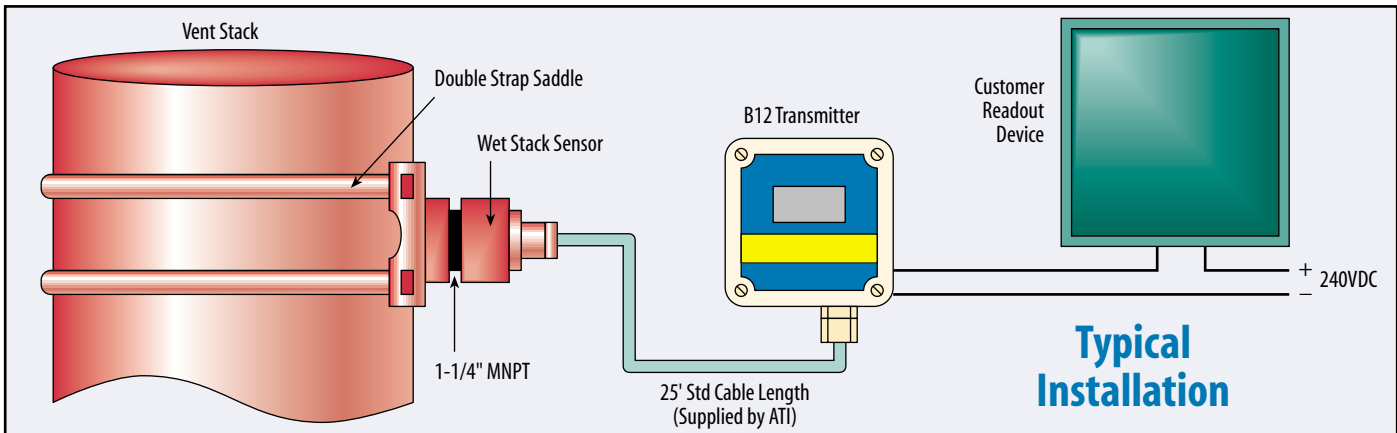

Specifications

Gas Type:

Oxidant gases: Cl₂, Br₂, ClO₂, O₃
 Acid gases: HF, HCl
 Hydrogen

Range:

0-10, 0-20, 0-50, or 0-100 ppm for oxidant or acid gases. 0-2% or 0-10% for hydrogen.

Accuracy:

Generally ±5% of value, but limited by available calibration gas accuracy.

Electronic Repeatability:

±1% of span

Electronic Linearity:

±0.5% of span

Output:

Loop-powered 4-20 mA, 675 ohms maximum at 24 VDC

Power:

12-28 VDC

Enclosure:

NEMA 4X polystyrene, LCD display optional. Explosion-proof optional, Class 1, Div 1, Groups B, C, & D.

Controls:

Zero and span potentiometers mounted on transmitter circuit board

Operating temperature:

0° to +50°C

Sensor materials:

Noryl

Sensor cable:

25 feet standard, 100 feet maximum.

Weight:

1 lb (0.4 kg)

Ordering Information: Model B12-CC-D-EEEE-F

Suffix CC - Gas Type

69 - Oxidant gas (specify Cl₂, Br₂, O₃, or ClO₂)
 70 - Acid gas (specify HCl or HF)
 71 - Hydrogen

Suffix D - Transmitter Type

2 - Explosion-proof
 5 - Standard NEMA 4X noryl
 6 - NEMA 4X with LCD display

Suffix E - Measurement Range

Code the measurement range using a 4-digit number. See specifications above for available ranges. For example, a standard wet chlorine transmitter with a range of 0-10 ppm would be coded 0010. A hydrogen system with a range of 0-2% would be coded 0002. Consult factory for availability of special ranges.

Suffix F - Units of Measurement

1 - PPM
 3 - %

Accessories

00-0633 - Flowcell assembly/calibration adapter
 Receiver - Series B14 alarm system (see separate B14 data sheet)



Analytical Technology, Inc.
 6 Iron Bridge Drive • Collegeville, PA 19426
 Phone: 610/917-0991 • Toll-Free: 800/959-0299
 Fax: 610/917-0992
 E-Mail: sales@analyticaltechnology.com
 Web: www.analyticaltechnology.com

ATI (UK) Limited
 Bank Chambers, 33 Stamford Street
 Mossley, Aston-u-Lyne OL5 0LL
 Phone: +44 (0) 1457 832800
 Fax: +44 (0) 1457 83950
 E-Mail: sales@atiuk.com

Represented By:

AFC International Inc
 PO Box 894 • DeMotte IN
 800.952.3293
 219.987.6825
 fax 219.987.6826
 sales@afcintl.com
 www.afcintl.com